

BUCK & BOOST TRANSFORMER INSTALLATION INSTRUCTIONS

Steps for Selecting the Proper Buck-Boost Transformer

First, you should have this information before selecting a buck-boost transformer.

Line Voltage—The voltage that you want to buck (decrease) or boost (increase). This can be found by measuring the supply line voltage with a voltmeter.

Load Voltage—The voltage at which your equipment is designed to operate. This is listed on the nameplate of the load equipment.

Load KVA or Load Amps — You do not need to know both—one or the other is sufficient for selection purposes. This information usually can be found on the nameplate of the equipment that you want to operate.

Frequency—The supply line frequency must be the same as the frequency of the equipment to be operated—either 50 or 60 cycles.

Phase—The supply line should be the same as the equipment to be operated—either single or three phase.

4 Step Selection

1 A series of LINE VOLTAGE and LOAD VOLTAGE combinations are listed across the top of each selection chart. Select a LINE VOLTAGE and LOAD VOLTAGE combination from ANY of the charts that comes closest to matching the LINE VOLTAGE and LOAD VOLTAGE of your application.

2 Read down the column you have selected until you reach either the LOAD KVA or LOAD AMPS of the equipment you want to operate. You probably will not find the exact value of LOAD KVA or LOAD AMPS so go to the next higher rating.

3 From this point, read across the column to the far left-hand side and you have found the catalog number of the exact buck-boost transformer you need.

4 CONNECT the transformer according to the connection diagram specified at the bottom of the column where you selected your LINE VOLTAGE and LOAD VOLTAGE combination.

Connection Diagrams – Single Phase

Autotransformer Overcurrent Protection

- The symbol "O" used in these single phase connection diagrams illustrates where to field install an overcurrent protective device (typically a fuse or circuit breaker) when one input conductor is grounded and the other input conductor is ungrounded.
- When both input conductors are ungrounded, an overcurrent protection device is required to be installed in series with each input conductor.
- When the input and output are reversed, always install the overcurrent protection device in series with the input conductor(s), as noted in items No. 1 and No. 2 shown above.
- For additional information, refer to the National Electrical Code, Article 450-4.

Only 1 Transformer is Required in Figure Shown Below

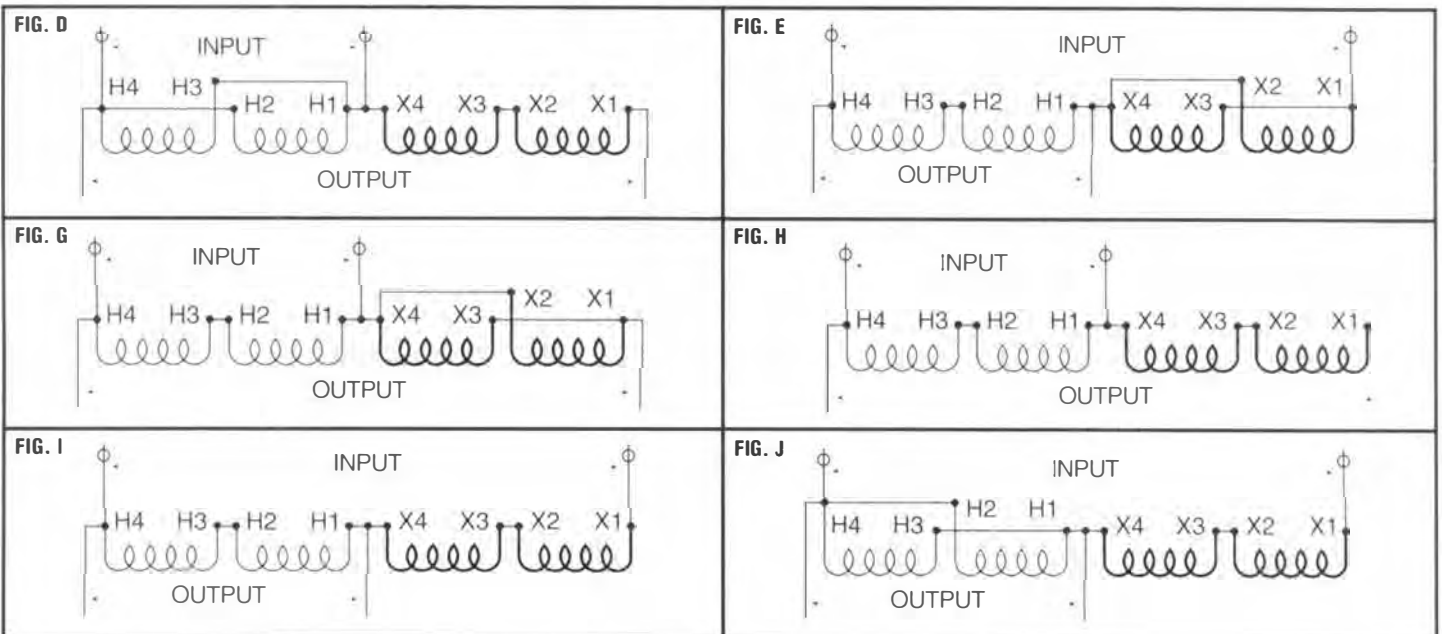

CAUTION: DO NOT USE CONNECTIONS OTHER THAN THOSE SHOWN OR PROVIDED BY FACTORY

INPUT VOLTAGE 240 X 480: OUTPUT VOLTAGE 24 X 48: 60 Hz

* All Sizes Of 3/4 KVA And Less Are Suitable For 50/60 Hz

Units Rated 240 x 480 V Input: 24 x 48 V Output		
INPUT	OUTPUT	CONNECTION DIAGRAM
240	24	K
240	48	L
480	24	M
480	48	N

CATALOG NUMBER	INSULATING TRANSFORMER RATING	MAX. CURRENT OUTPUT	
		24 V	48 V
M181061	** 50 VA	2.08	1.04
M181062	** 100 VA	4.16	2.08
M181063	** 150 VA	6.24	3.12
M181064	** 0.25 KVA	10.40	5.20
M181065	** 0.50 KVA	20.80	10.40
M181066	** 0.75 KVA	31.20	15.60
M137920	1.00 KVA	41.60	20.80
M137921	1.50 KVA	62.40	31.20
M137922	2.00 KVA	83.20	41.60
M137923	3.00 KVA	125.00	62.50
M137924	5.00 KVA	208.00	104.00
M243570	7.50 KVA	312.00	156.00
M243571	10.00 KVA	416.00	208.00

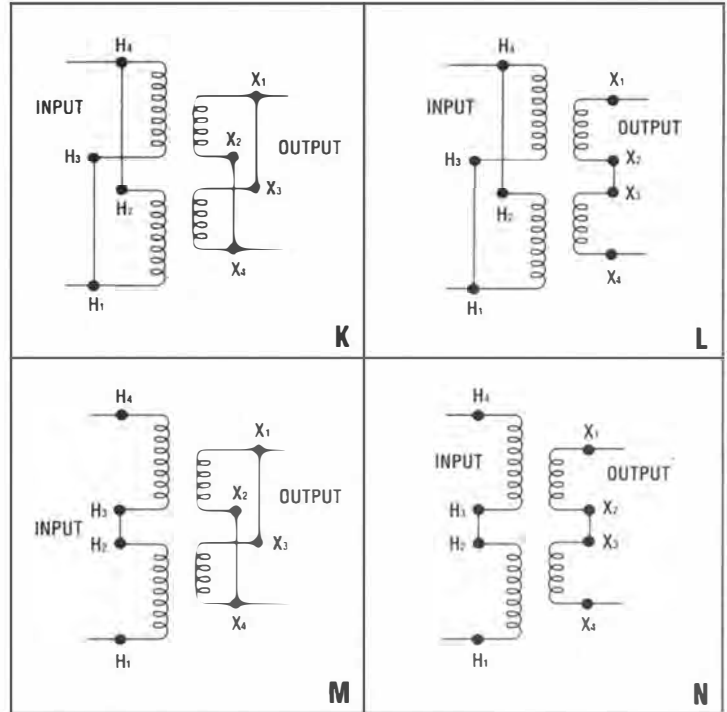

Three Phase Connections

CAUTION: DO NOT USE CONNECTIONS OTHER THAN THOSE SHOWN OR PROVIDED BY FACTORY.

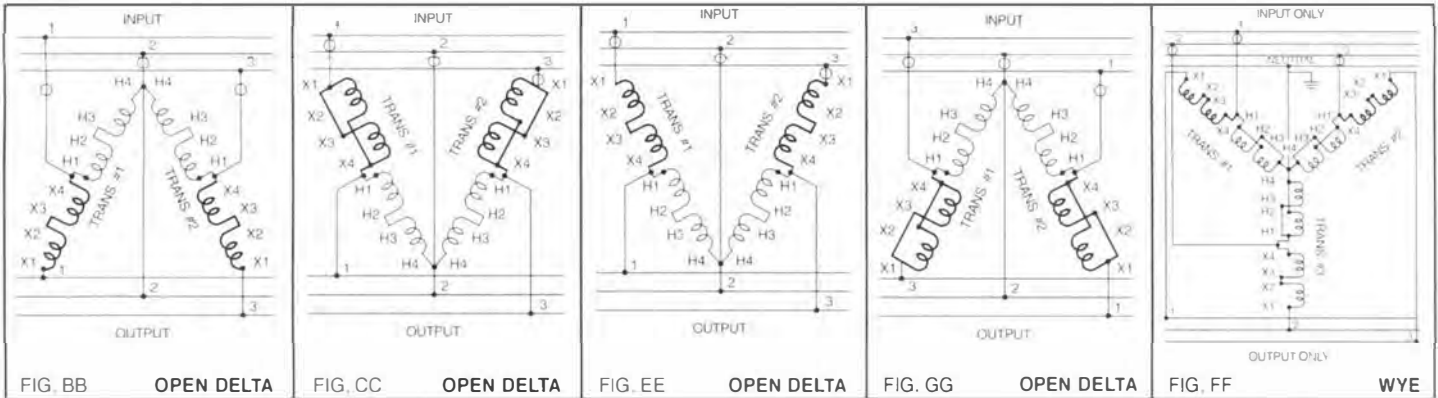

Typical Buck-Boost Autotransformer Installation

The number of Buck-Boost Transformers is shown on the connection used, it may vary from the number shown in this illustration.

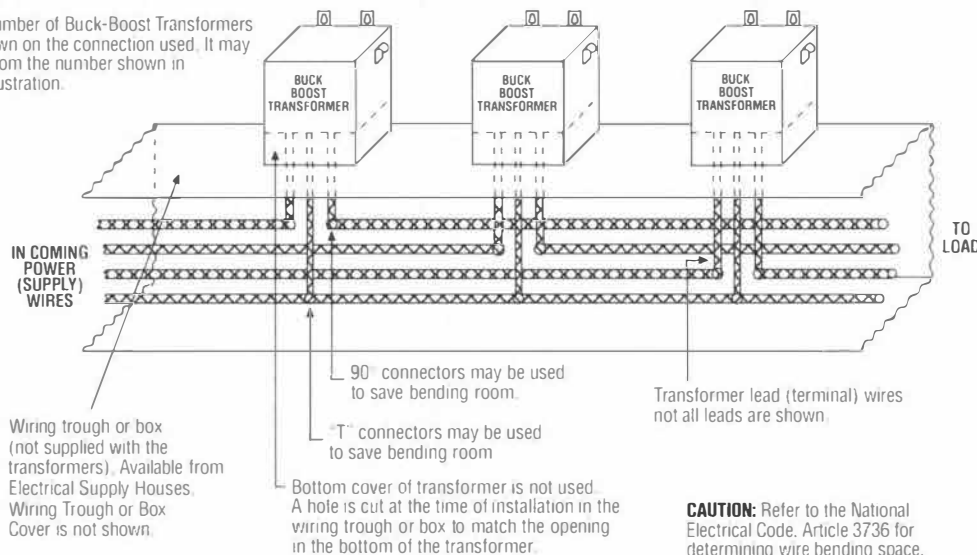

Autotransformer Overcurrent Protection

The symbol "O" used in these three phase connection diagrams illustrates where to field install an overcurrent protective device (typically a fuse or circuit breaker).

When the input and output are reversed, always install the overcurrent protection device in series with the input conductors.

For additional information, refer to the National Electrical Code, Article 450-4.

USE INFORMATION BELOW FOR SINGLE PHASE AUTOTRANSFORMER CONNECTIONS

GROUP III

SINGLE PHASE

SINGLE PHASE		BOOSTING										BUCKING				
Line Voltage (Available)		230	380	416	425	430	435	440	440	450	460	277	480	480	504	
Load Voltage (Output)		277	420	457	467	473	457	462	484	472	483	230	436	456	480	
CAT. NO. ▲ (SEE FOOTNOTE)																
M181061	Load	KVA Amps	0.29 1.04	0.44 1.04	0.48 1.04	0.49 1.04	0.49 1.04	0.95 2.08	0.96 2.08	0.50 1.04	0.98 2.08	1.01 2.08	0.29 1.25	0.50 1.15	1.05 2.29	1.10 2.29
	Max. Size of Fuse or Breaker		3	3	3	3	3	6	6	3	6	6	3	3	6	6
M181062	Load	KVA Amps	0.58 2.08	0.87 2.08	0.95 2.08	0.97 2.08	0.99 2.08	1.90 4.17	1.93 4.17	1.01 2.08	1.97 4.17	2.01 4.17	0.58 2.50	1.00 2.29	2.09 4.58	2.20 4.58
	Max. Size of Fuse or Breaker		6	6	6	6	6	10	10	6	10	10	6	6	10	10
M181063	Load	KVA Amps	0.87 3.13	1.31 3.13	1.43 3.13	1.46 3.13	1.48 3.13	2.86 6.25	2.89 6.25	1.51 3.13	2.95 6.25	3.02 6.25	0.86 3.75	1.50 3.44	3.14 6.88	3.30 6.88
	Max. Size of Fuse or Breaker		10	6	6	6	6	15	15	6	15	15	6	6	15	15
M181064	Load	KVA Amps	1.44 5.21	2.19 5.21	2.38 5.21	2.43 5.21	2.46 5.21	4.76 5.21	4.81 10.42	2.52 5.21	4.92 10.42	5.03 10.42	1.44 6.25	2.50 5.73	5.23 11.46	5.50 11.46
	Max. Size of Fuse or Breaker		15	10	10	10	10	15	15	10	15	15	10	10	15	15
M181065	Load	KVA Amps	2.89 10.42	4.38 10.42	4.76 10.42	4.86 10.42	4.93 10.42	9.52 20.83	9.62 20.83	5.04 10.42	9.83 20.83	10.06 20.83	2.88 12.50	5.00 11.46	10.45 22.92	11.00 22.92
	Max. Size of Fuse or Breaker		20	15	15	15	15	30	30	15	30	30	15	15	30	30
M181066	Load	KVA Amps	4.33 15.63	6.56 15.63	7.14 15.63	7.30 15.63	7.39 15.63	14.28 31.25	14.44 31.25	7.56 15.63	14.75 31.25	15.09 31.25	4.31 18.75	7.49 17.19	15.68 34.38	16.50 34.38
	Max. Size of Fuse or Breaker		25	25	25	25	25	45	45	25	45	45	20	20	45	45
M137920	Load	KVA Amps	5.77 20.83	8.57 20.83	9.52 20.83	9.73 20.83	9.85 20.83	19.04 41.67	19.25 41.67	10.08 20.83	19.67 41.67	20.13 41.67	5.75 25.00	9.99 22.92	20.90 45.83	22.00 45.83
	Max. Size of Fuse or Breaker		35	30	30	30	30	60	60	30	60	60	30	30	60	60
M137921	Load	KVA Amps	8.66 31.25	13.13 31.25	14.28 31.25	14.59 31.25	14.78 31.25	28.56 62.50	28.88 62.50	15.13 31.25	29.50 62.50	30.19 62.50	8.63 37.50	14.99 34.38	31.35 68.75	33.00 68.75
	Max. Size of Fuse or Breaker		50	50	45	45	45	90	90	45	90	90	40	40	90	90
M137922	Load	KVA Amps	11.54 41.67	17.50 41.67	19.04 41.67	19.46 41.67	19.71 41.67	38.08 83.33	38.50 83.33	20.17 41.67	39.33 83.33	40.25 83.33	11.50 50.00	19.98 45.83	41.80 91.67	44.00 91.67
	Max. Size of Fuse or Breaker		70	60	60	60	60	110	110	60	110	110	60	60	110	110
M137923	Load	KVA Amps	17.31 62.50	26.25 62.50	28.56 62.50	29.19 62.50	29.56 62.50	57.13 125.00	57.75 125.00	30.25 62.50	59.00 125.00	60.38 125.00	17.25 75.00	29.98 68.80	62.70 137.50	66.00 137.50
	Max. Size of Fuse or Breaker		100	90	90	90	90	175	175	90	175	175	80	80	175	175
M137924	Load	KVA Amps	28.90 104.20	43.80 104.20	47.60 104.20	48.60 104.20	49.30 104.20	95.20 208.30	96.20 208.30	50.40 104.20	98.30 208.30	100.60 208.30	28.80 125.00	50.00 114.60	104.50 229.20	110.00 229.20
	Max. Size of Fuse or Breaker		175	150	150	150	150	300	300	150	300	300	150	150	300	300
M243570	Load	KVA Amps	43.30 156.30	65.60 156.30	71.40 156.30	73.00 156.30	73.90 156.30	142.80 312.50	144.40 312.50	75.60 156.30	147.50 312.50	150.90 312.50	43.10 187.50	74.90 171.90	156.80 343.80	165.00 343.80
	Max. Size of Fuse or Breaker		250	225	225	225	225	450	450	225	450	450	200	200	450	450
M243571*	Load	KVA Amps	57.70 208.30	87.50 208.30	95.20 208.30	97.30 208.30	98.50 208.30	190.40 416.70	192.50 416.70	100.80 208.30	196.70 416.70	201.30 416.70	57.50 250.00	99.90 229.20	209.00 458.30	220.00 458.30
	Max. Size of Fuse or Breaker		350	300	300	300	300	600	600	300	600	600	300	300	600	600
Connection Diagram		D	H	H	H	H	G	G	H	G	G	J	I	E	E	

NOTE: Inputs and Outputs may be reversed; KVA capacity remains constant. All applications above bold face line are suitable for 50/60 Hz. All applications below bold face line are suitable for 60 Hz only.

IMPORTANT: Refer to the N.E.C. (National Electrical Code) Article 450-4 for Overcurrent Protection of an Autotransformer.

▲ The first digit of the catalog number appearing on the transformer name plate may be different than what is shown on this instruction sheet:
EXAMPLE: T-1 or T-2 or T-3 and ETC.

Larger KVA buck-boost transformers utilize multiple conductors on the secondary (X) terminals as shown below.

M243571	NUMBER OF LEADS PER TERMINATION							
	H1	H2	H3	H4	X1	X2	X3	X4
	1	1	1	1	2	2	2	2

All leads with same designation (ex. X1, X1) MUST be joined together for proper operation.

USE INFORMATION BELOW FOR THREE PHASE AUTOTRANSFORMER CONNECTIONS

GROUP III

THREE PHASE		BOOSTING							
Line Voltage (Available)	399Y 230	380	430	440	460	460	480	480	
Load Voltage (Output)	480	420	473	462	506	483	528	504	
CAT. NO. ▲ (SEE FOOTNOTE) SHOWN ON PAGE 2									
M181061	Load KVA Amps	0.86 1.04	0.76 1.04	0.85 1.04	1.66 2.08	0.91 1.04	1.74 2.08	0.95 1.04	1.82 2.08
	Max. Size of Fuse or Breaker	3	3	3	6	3	6	3	6
M181062	Load KVA Amps	1.73 2.08	1.51 2.08	1.70 2.08	3.33 4.16	1.82 2.08	3.48 4.16	1.90 2.08	3.63 4.16
	Max. Size of Fuse or Breaker	6	6	6	10	6	10	6	10
M181063	Load KVA Amps	2.60 3.12	2.27 3.12	2.56 3.12	4.99 6.24	2.73 3.12	5.22 6.25	2.85 3.12	5.45 6.24
	Max. Size of Fuse or Breaker	10	6	6	15	6	15	6	15
M181064	Load KVA Amps	4.33 5.20	3.78 5.20	4.26 5.20	8.32 10.40	4.56 5.20	8.70 10.40	4.76 5.20	9.08 10.40
	Max. Size of Fuse or Breaker	15	10	10	15	10	15	10	15
M181065	Load KVA Amps	8.60 10.40	7.56 10.40	8.52 10.40	16.64 20.80	9.11 10.40	17.40 20.80	9.51 10.40	18.16 20.80
	Max. Size of Fuse or Breaker	20	15	15	30	15	30	15	30
M181066	Load KVA Amps	12.90 15.60	11.34 15.60	12.77 15.60	24.97 31.20	13.67 15.60	26.10 31.20	14.27 15.60	27.24 31.20
	Max. Size of Fuse or Breaker	25	25	25	45	25	45	25	45
M137920	Load KVA Amps	17.30 20.80	15.12 20.80	17.03 20.80	33.29 41.60	18.23 20.80	34.80 41.60	19.02 20.80	36.31 41.60
	Max. Size of Fuse or Breaker	35	30	30	60	30	60	30	60
M137921	Load KVA Amps	25.90 31.20	22.69 31.20	25.55 31.20	49.93 62.40	27.34 31.20	52.20 62.40	28.53 31.20	54.47 62.40
	Max. Size of Fuse or Breaker	50	45	45	90	45	90	45	90
M137922	Load KVA Amps	34.60 41.60	30.25 41.60	34.07 41.60	66.58 83.20	36.46 41.60	69.60 83.20	38.04 41.60	72.63 83.20
	Max. Size of Fuse or Breaker	70	60	60	110	60	110	60	110
M137923	Load KVA Amps	52.00 62.50	45.45 62.50	51.18 62.50	100.03 125.00	54.69 62.50	104.57 125.00	57.07 62.50	109.12 125.00
	Max. Size of Fuse or Breaker	100	90	90	175	90	175	90	175
M137924	Load KVA Amps	86.10 104.00	75.62 104.00	85.17 104.00	166.44 208.00	91.15 104.00	174.01 208.00	95.11 104.00	181.57 208.00
	Max. Size of Fuse or Breaker	175	150	150	300	150	300	150	300
M243570	Load KVA Amps	129.30 156.00	113.43 156.00	127.75 156.00	249.66 312.00	136.72 156.00	261.01 312.00	142.67 156.00	272.36 312.00
	Max. Size of Fuse or Breaker	250	225	225	450	225	450	225	450
M243571*	Load KVA Amps	173.10 208.00	151.25 208.00	170.33 208.00	332.89 416.00	182.29 208.00	348.02 416.00	190.22 208.00	363.15 416.00
	Max. Size of Fuse or Breaker	350	300	300	600	300	600	300	600
Quantity Required	3	2	2	2	2	2	2	2	
Connection Diagram	F-F	B-B	B-B	G-G	B-B	G-G	B-B	G-G	

THREE PHASE

BUCKING							
440	440	460	460	480	480	500	500
400	419	438	418	457	436	455	477
0.79 1.14	1.58 2.18	1.66 2.18	0.83 1.14	1.73 2.18	0.86 1.14	0.90 1.14	1.80 2.18
3	6	6	3	6	3	3	6
1.59 2.29	3.17 4.37	3.31 4.37	1.66 2.29	3.46 4.37	1.73 2.29	1.80 2.29	3.61 4.37
6	10	10	6	10	6	6	10
2.38 3.43	4.75 6.55	4.97 6.55	2.48 3.43	5.19 6.55	2.59 3.43	2.70 3.43	5.41 6.55
6	15	15	6	15	6	6	15
3.96 5.72	7.92 10.92	8.28 10.92	4.14 5.72	8.64 10.92	4.32 5.72	4.51 5.72	9.02 10.92
10	15	15	10	15	10	10	15
7.93 11.44	15.85 21.84	16.57 21.84	8.28 11.44	17.29 21.84	8.64 11.44	9.02 11.44	18.04 21.84
15	30	30	15	30	15	15	30
11.89 17.16	23.77 32.76	24.85 32.76	12.42 17.16	25.93 32.76	12.96 17.16	13.52 17.16	27.07 32.76
20	40	40	20	40	20	20	40
15.85 22.88	31.70 43.68	33.14 43.68	16.57 22.88	34.57 43.68	17.28 22.88	18.03 22.88	36.09 43.68
30	60	60	30	60	30	30	60
23.78 34.32	47.55 65.52	49.71 65.52	24.85 34.32	51.86 65.52	25.92 34.32	27.05 34.32	54.13 65.52
40	80	80	40	80	40	40	80
31.70 45.76	63.40 87.36	66.27 87.36	33.13 45.76	69.15 87.36	34.56 45.76	36.06 45.76	72.18 87.36
60	110	110	60	110	60	60	110
47.63 68.75	95.25 131.25	99.57 131.25	49.77 68.75	103.89 131.25	51.92 68.75	54.18 68.75	108.44 131.25
80	175	175	80	175	80	80	175
79.26 114.40	158.50 218.40	165.69 218.40	82.83 114.40	172.87 218.40	86.39 114.40	90.16 114.40	180.44 218.40
150	300	300	150	300	150	150	300
118.89 171.60	237.75 327.60	248.53 327.60	124.24 171.60	259.31 327.60	129.59 171.60	135.23 171.60	270.66 327.60
200	400	400	200	400	200	200	400
158.52 228.80	317.00 436.80	331.37 436.80	165.65 228.80	345.75 436.80	172.78 228.80	180.31 228.80	360.88 436.80
300	600	600	300	600	300	300	600
2	2	2	2	2	2	2	2
E-E	C-C	C-C	E-E	C-C	E-E	E-E	C-C

NOTE: (1) Inputs and Outputs may be reversed; KVA capacity remains constant. All applications above bold face line are suitable for 50/60 Hz. All applications below bold face line are suitable for 60 Hz only.
(2) Connection Diagrams A-A and F-F cannot be reverse connected.

IMPORTANT: Refer to the N.E.C. (National Electrical Code) Article 450-4 for Overcurrent Protection of an Autotransformer.

Larger KVA buck-boost transformers utilize multiple conductors on the secondary (X) terminals as shown below

M243571	NUMBER OF LEADS PER TERMINATION							
	H1	H2	H3	H4	X1	X2	X3	X4
	1	1	1	1	2	2	2	2

All leads with same designation (ex. X1, X1) MUST be joined together for proper operation.